

Viking ship GOKSTAD, 9th century

Scale: 1/35

Length: 610mm

Width: 270mm

Height: 370mm

HISTORY:

This model represents a Viking ship found in year 1880 near village Gokstad in Norway. The ship was built in second half of ninth century. Excellent nautical ability of the ship was demonstrated in the year 1893 when a replica built by Magnus Anderson took a journey from Norway to USA. Total length of the ship was 24m. A keel and planks were made from oak wood. The ship was propelled by 32 oars and one rectangular sail.

Recommended tool list:

- 1) Modeler's knife or scalpel
- 2) Mini drilling machine
- 3) Drill bits
- 4) Selection of abrasive paper
- 5) Scissors
- 6) Pliers
- 7) Clothes pegs or crocodile clips
- 8) Pencil
- 9) Rule
- 10) Set of needle files
- 12) Sewing machine
- 13) Mini lathe

Before you begin:

Before you begin to build the model it is necessary with a vengeance read building instructions and plans. Also chronology of assembly steps is necessary to keep. You check if the parts go together before you glue it respectively you make any corrections with sandpaper. During the gluing, painting, lacquering and at work with another chemical materials is necessary well ventilated in your working room. You cut the parts from sheet until actually required for fitting. You cut by knife only in direction off ward your body so that you head to injury risk.

Coloring:

Medieval ships were protected against influence of salt water and woodworms by a mixture of tar and thanks to it the hull of ships was a reddish-brown or brownish-black color. This effect it is possible to get by staining of the wood by dark wood stain. It is recommended to use the wood stain before gluing of the parts. Decks of the ships were probably in naturally color of wood. Anchors and other metal parts were a black color.

Model building process:

I) Framing of a hull:

a) First glue a keel from parts 0a, 0b and 0c. Then draw on both sides of the keel 0 contours of planking. The contours draw after the plans.

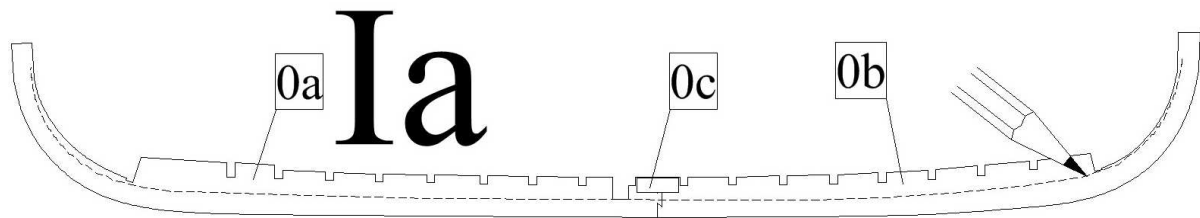

b) Run frames 2-18 into the keel 0 but do not glue them yet! Then run to the frames decks 20 and 21. Then glue together the decks, frames and keel. Finally glue to the keel also frames 1 and 19.

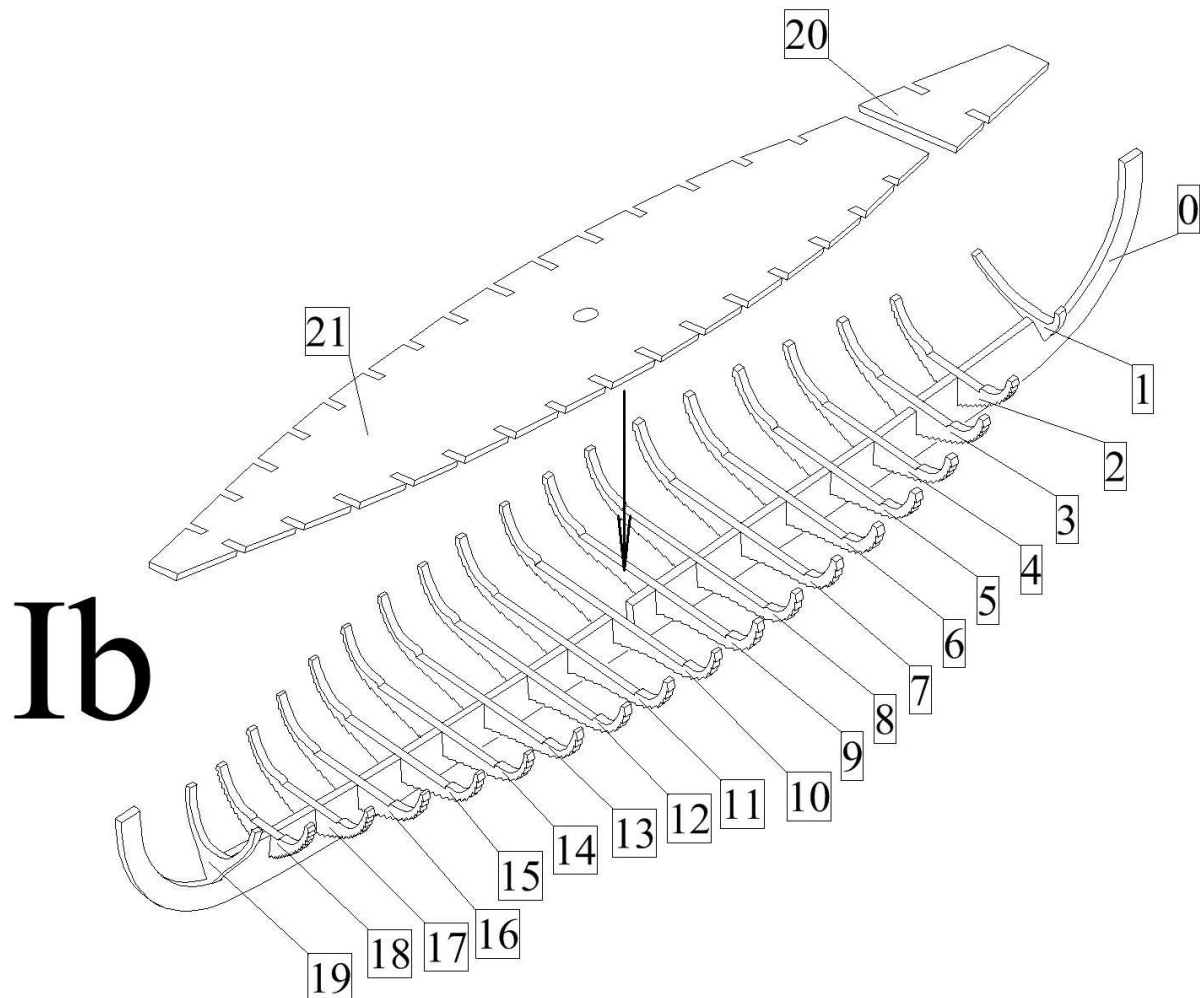

c) Glue a transverse planks 22-38 on the decks.

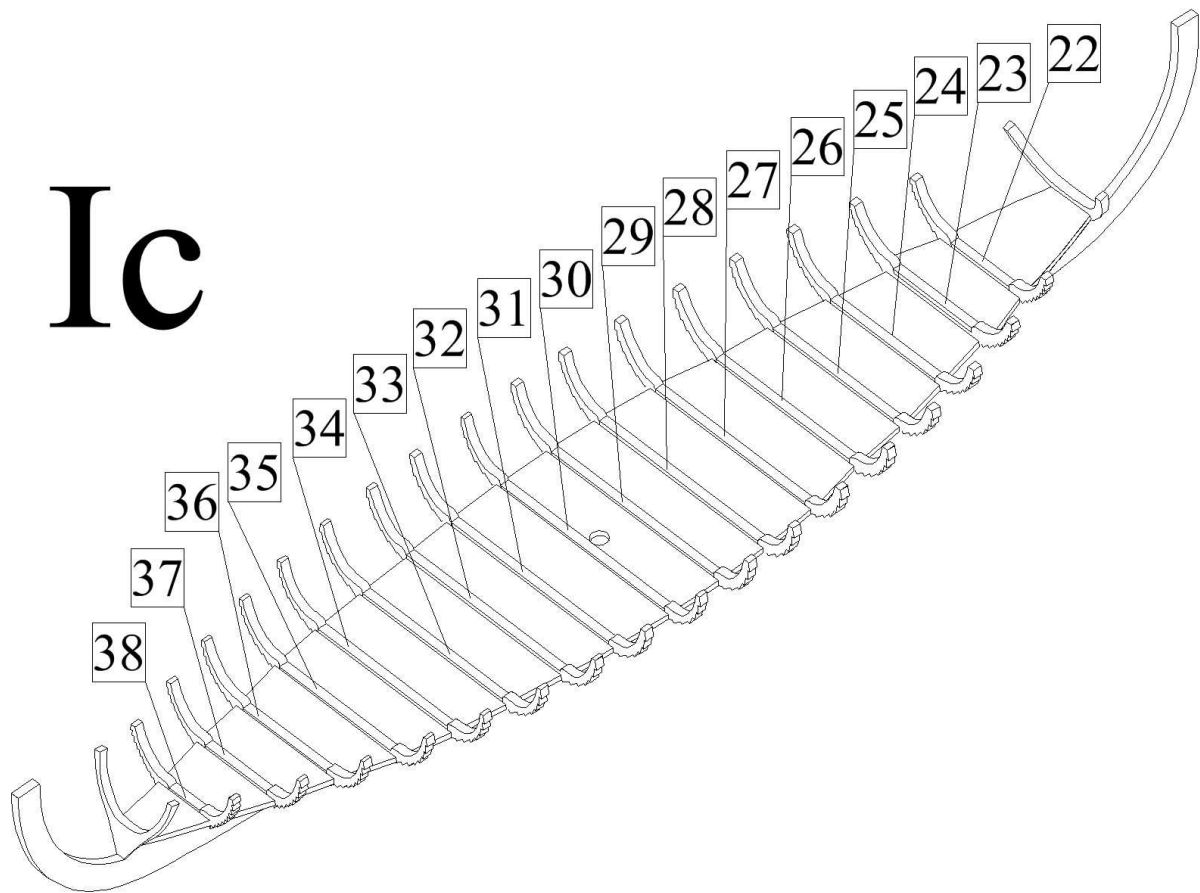

II) Hull planking I:

The hulls of Viking ships were built by clinker planking method. It means that neighbor planks are overlapped. For this reason it is very important to keep exact order of gluing of the planks! First glue lowest planks 39 to the frame of the hull. Before gluing of the planks to the frames it is also need to sharpen the ends of the planks. Then start to glue the planks to a middle part of the ship and subsequently glue it to bow to stern. Before you glue it to the stem and stern shorten the planks into required length. Then glue also other planks in sequence from 40 to 52. After gluing the planks to the hull grind by a sand paper the frames so that following planks tightly joined to the already glued planks. An arrow in the plan shows an orientation of the planks.

II

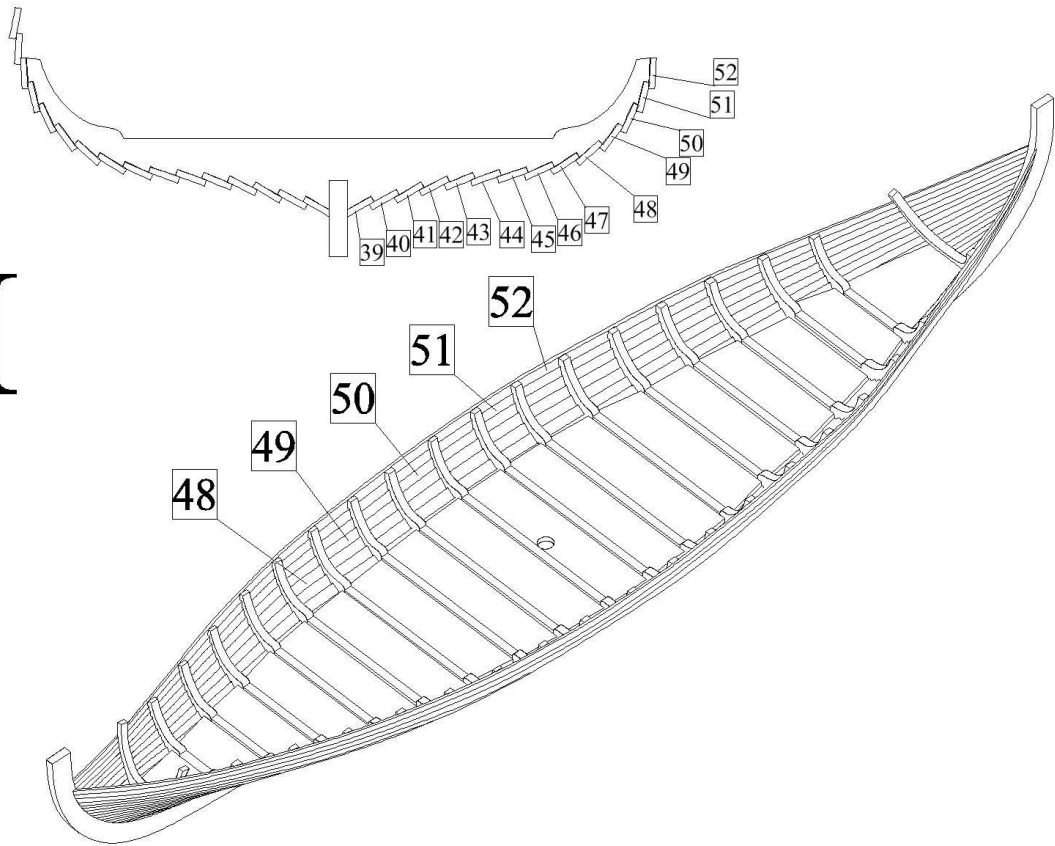

III) Deck:

Plank the deck by strips 0,5x7mm. The planking of the deck is shown in 1:1 scale in the plans.

III

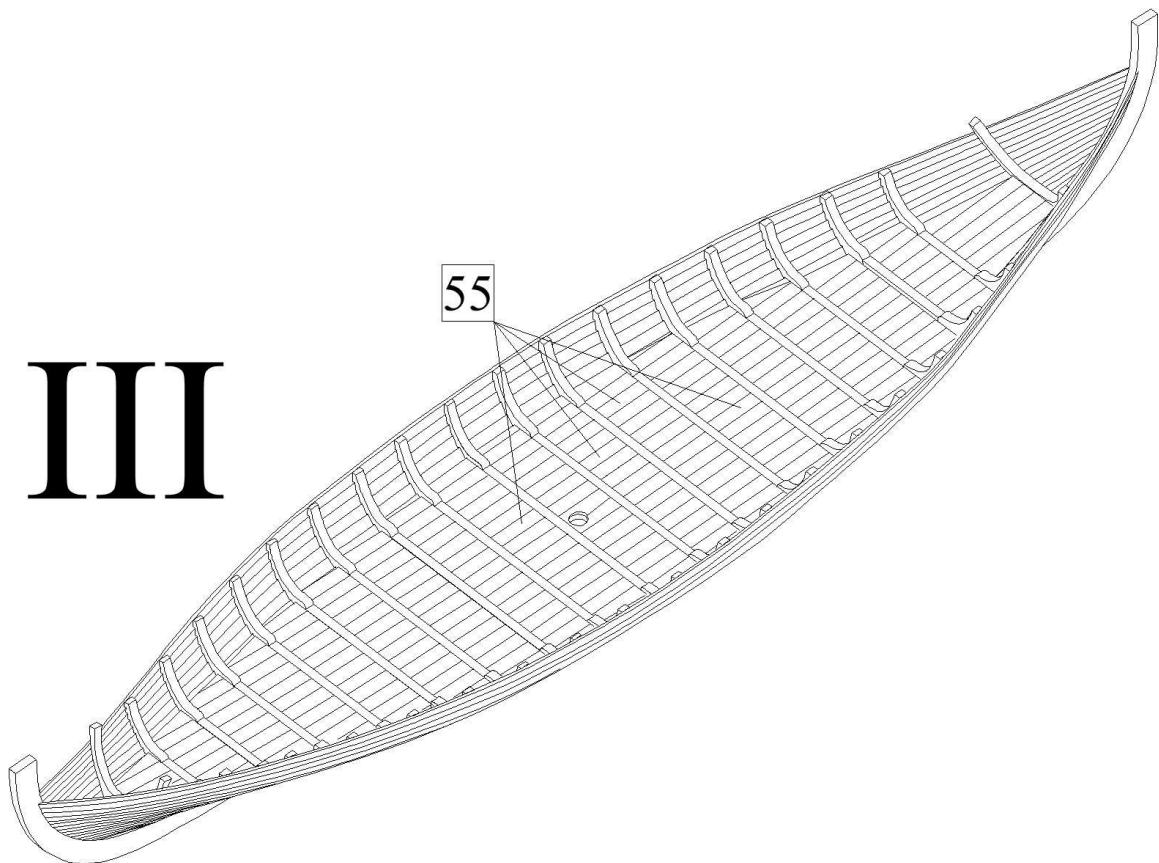

IV) Plaňování trupu II:

IV) Hull planking II:

First glue frames 2a, 4a,...,18a to the frames 2,4,...,18. Then finish the planking with planks 53 and 54. Then make heels of T-shaped supports 57 and glue them to the deck. Then glue cleats 56 to the stern. An exact position of the cleats is shown in 1:1 scale in the plans. Then to the hull drill 2mm holes for oars and 1mm holes for tying of shields. An exact position of the holes is in 1:1 scale shown in the plans.

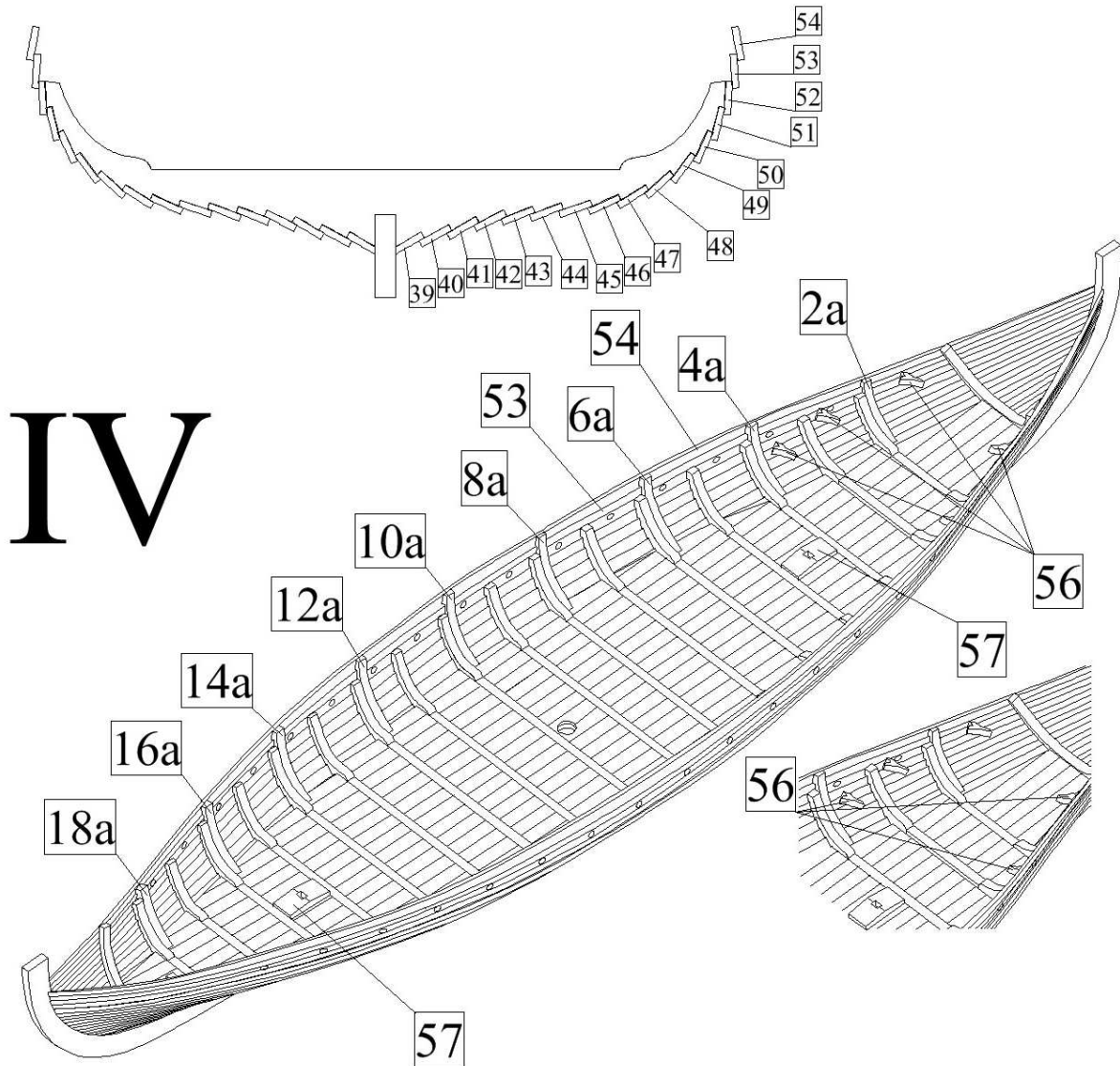

V) Mast foot:

First glue together parts 58-62. Then sharpen by sand paper or file the mast foot into needed shape. Then drill into the mast foot a 8mm hole. The mast foot is in 1:1 scale shown in the plans.

VI) T shape supports:

First glue the mast foot to the deck. Then glue to it reinforcements 63-66. Then glue from parts 67a, 68a, 67b, 68b and 69 the T shape supports. Then glue the T shape supports to its positions. An exact position of the T-shape supports is in 1:1 scale shown in the plans.

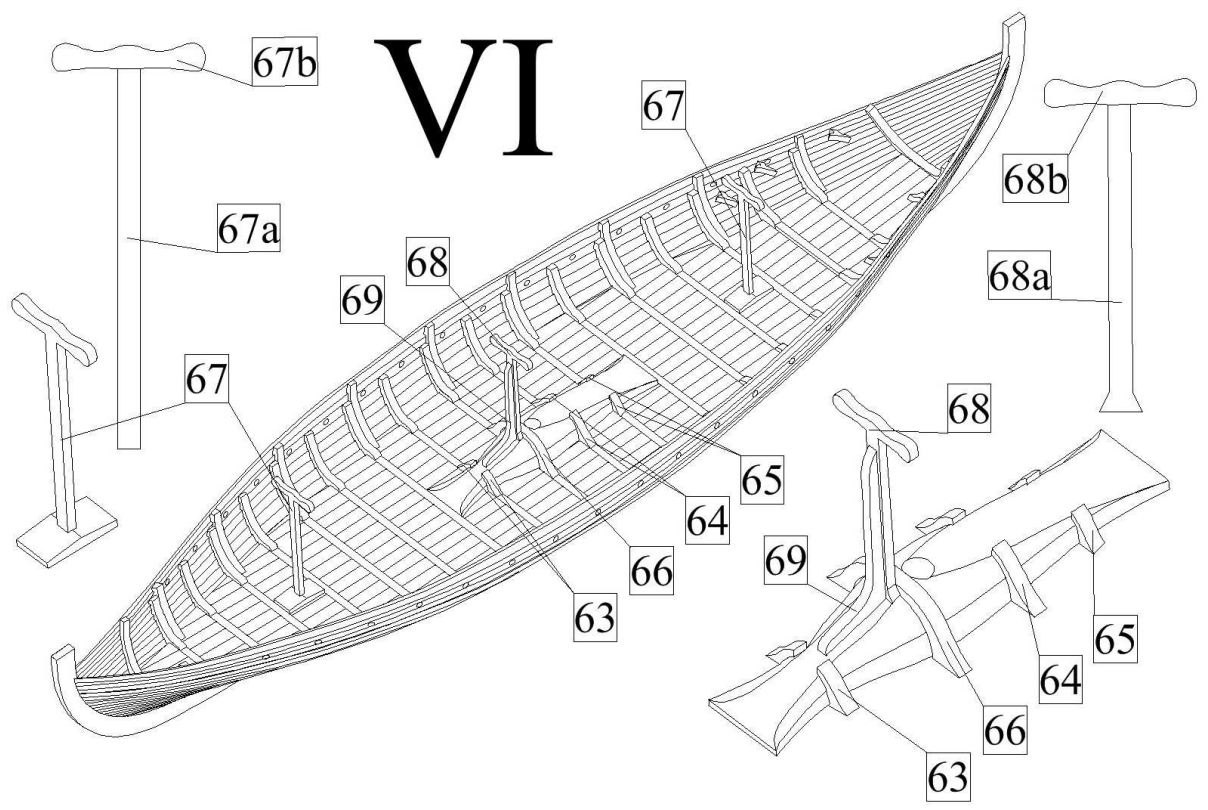
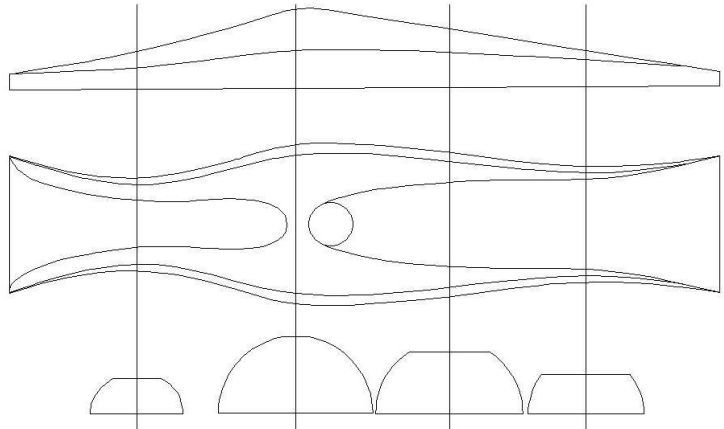
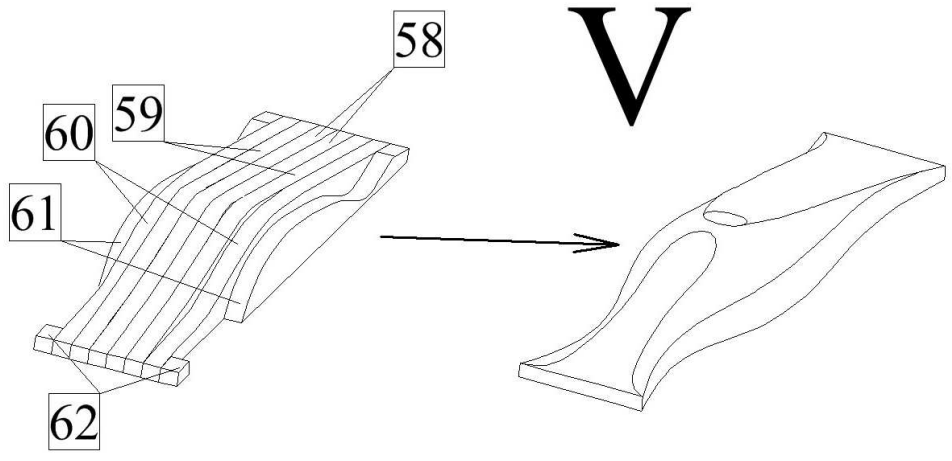

VII) Rudder oar:

First sharpen the rudder oar 74 by a sand paper or file into needed shape. Then glue a handle to the rudder oar. Then make parts 73 and 80 and glue them to the hull. The part 73 make from dowel 8mm and the part 80 make from strip 2x4mm. Finally tie the rudder oar to the hull like it is shown below.

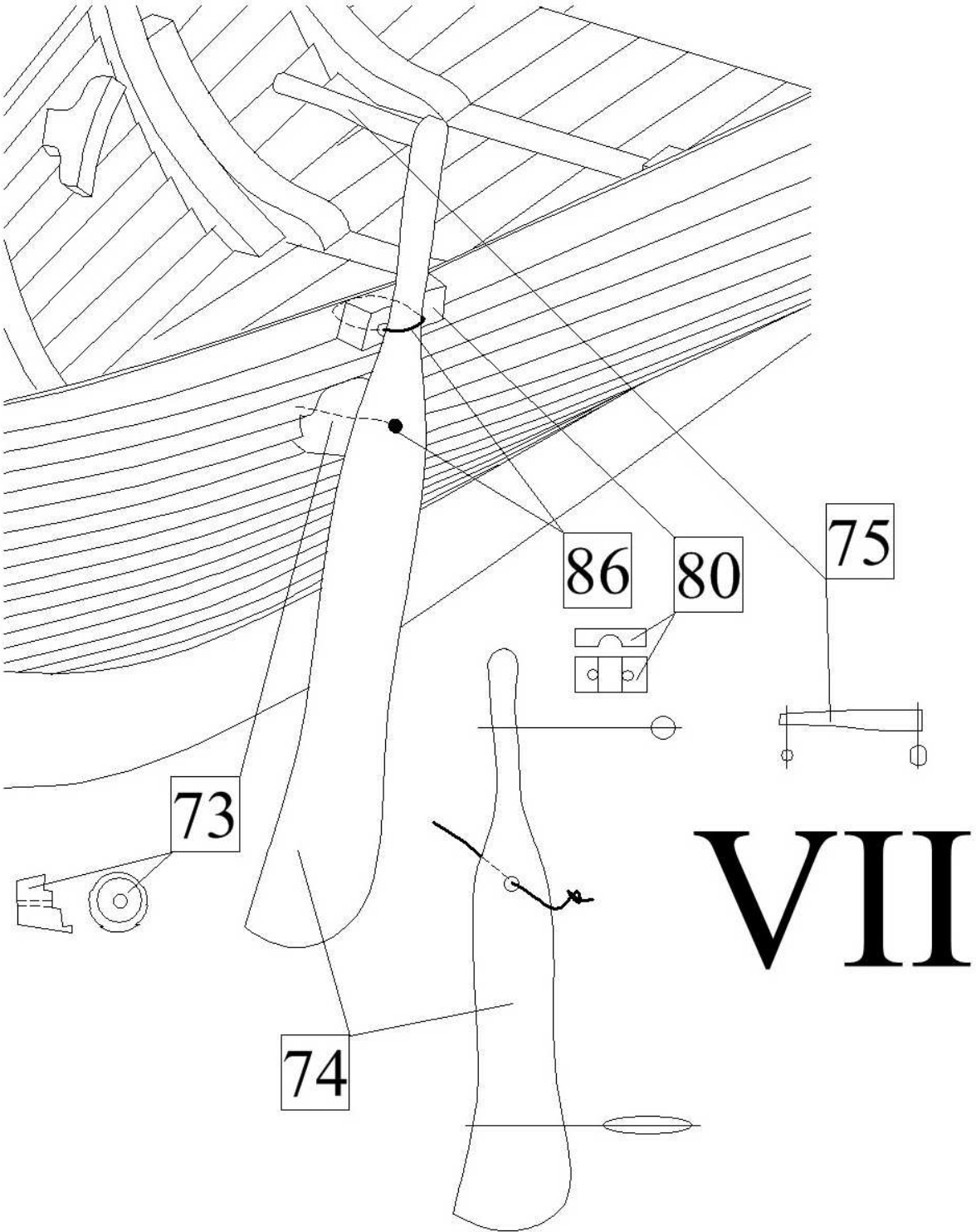

VII

VIII) Mast:

From 8mm dowel make a mast 70. Sharpen the mast by a sand paper into conical shape and on a top of the mast drill a 1mm hole. The mast is in 1:1 scale shown in the plans. Then glue the mast to the mast foot. Then Glue also board 72 to the mast foot. Then glue boards with holes 81 to the hull. Finally tie the mast to the hull by ropes 93 and cleats 84 after the figure below.

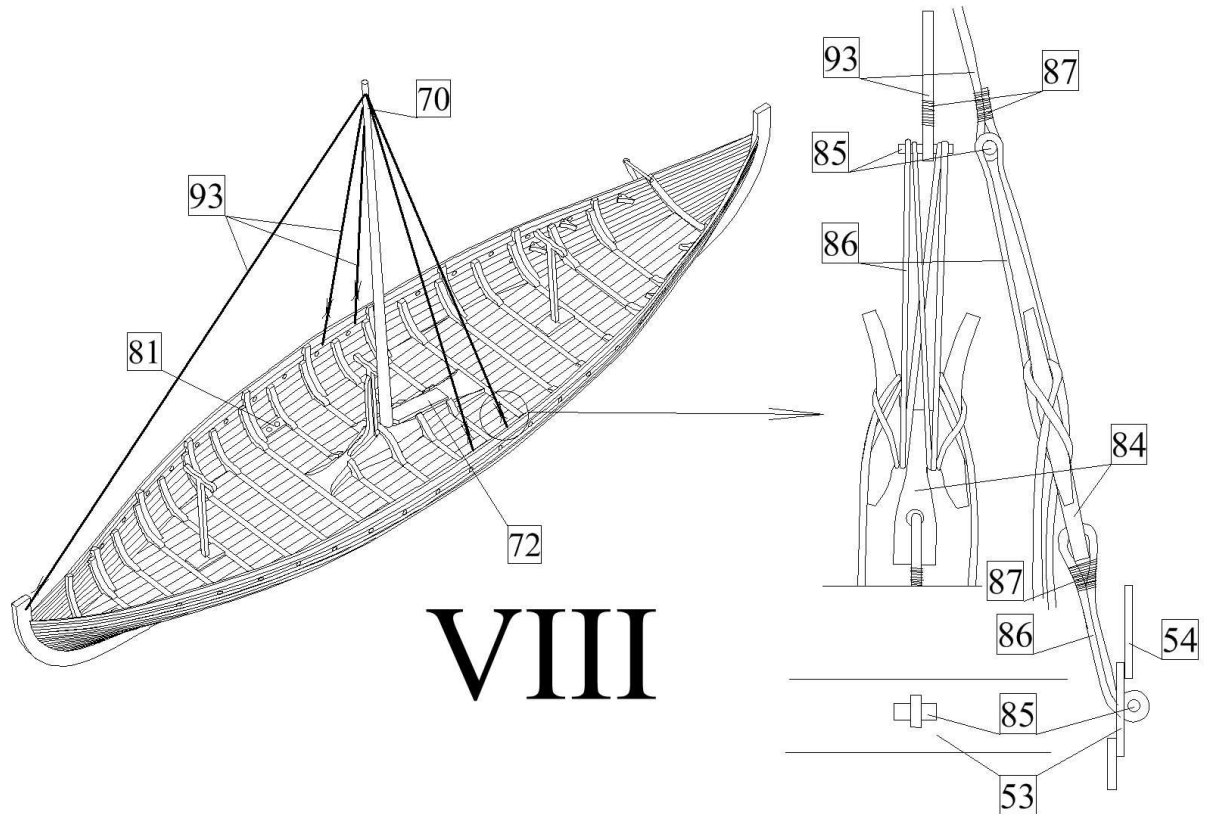

VIII

IX) Yard:

a) Sharpen the yard 71 by a sand paper from dowel 6mm. The yard is in 1:1 scale shown in the plans. Then tie the yard by a rope 86 to the mast after the figure below.

b) Tie the yard to the hull after the figure below.

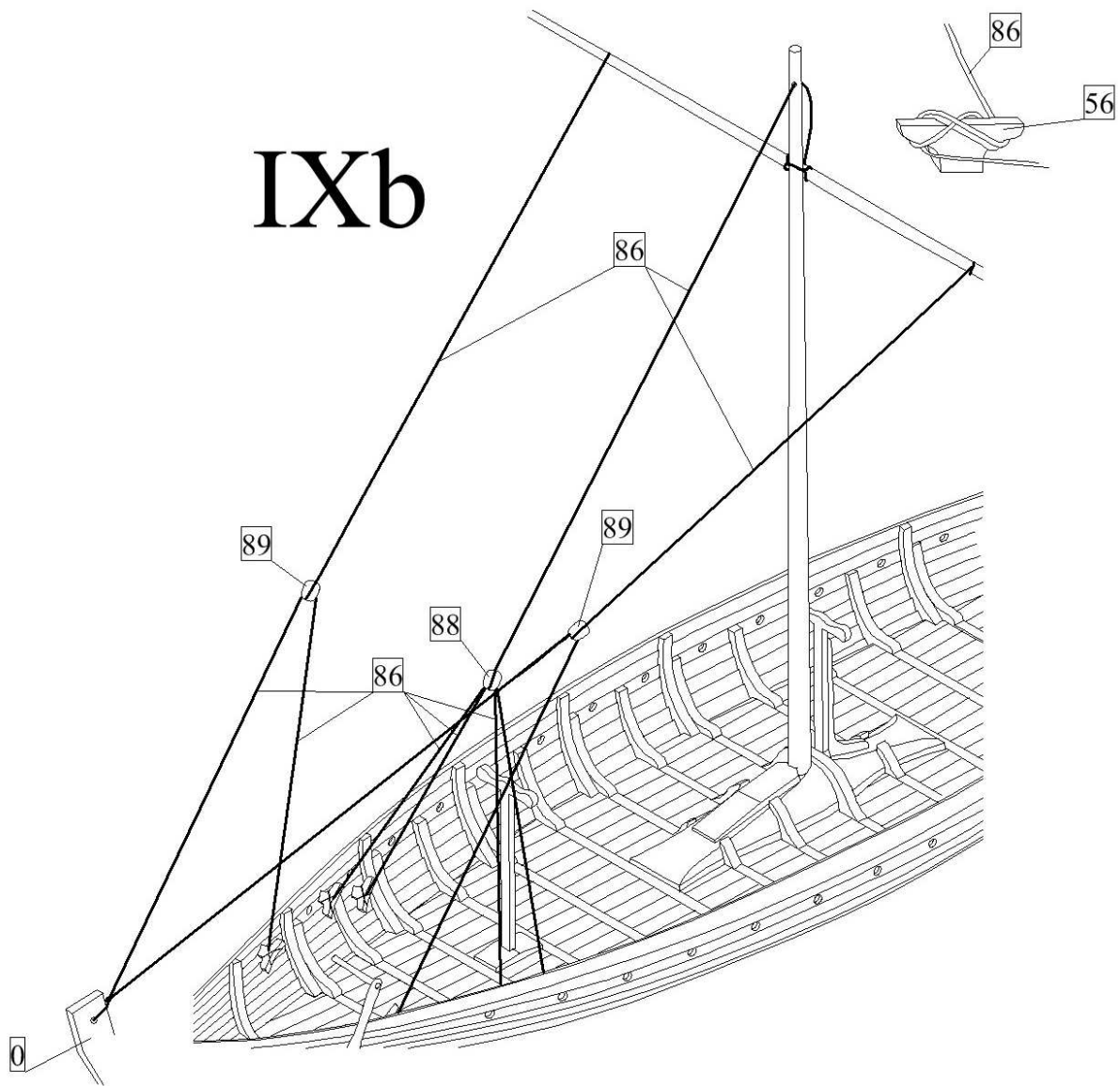
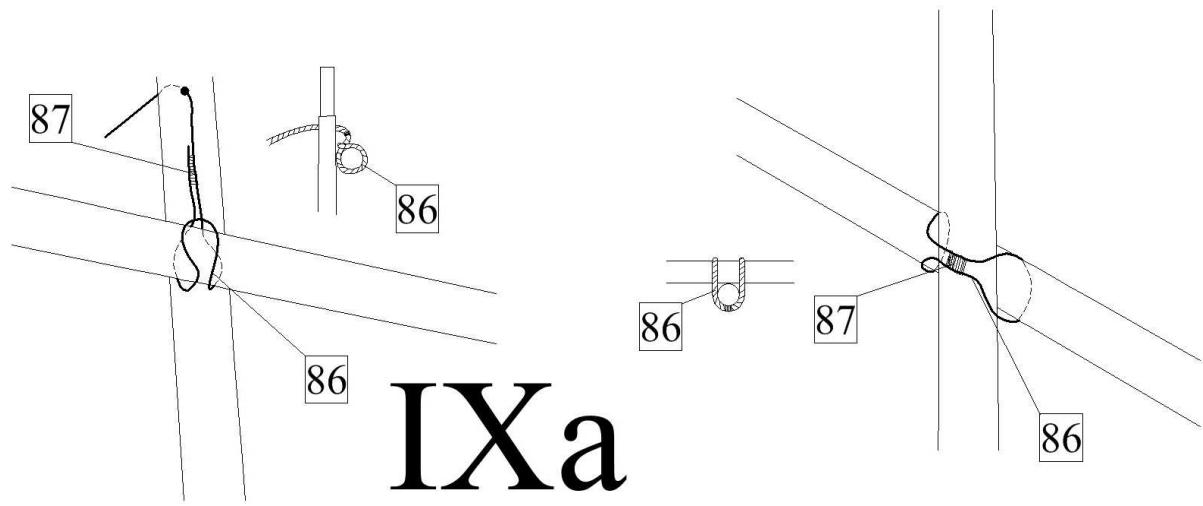

X) Shields:

First glue the parts 77 to the shields 76. Then glue also handles 78 to other side of the shields. The handles cut out from strip 1x1mm. Finally tie the shields by rope 87 to the hull. The shield is in 1:1 scale shown in the plan.

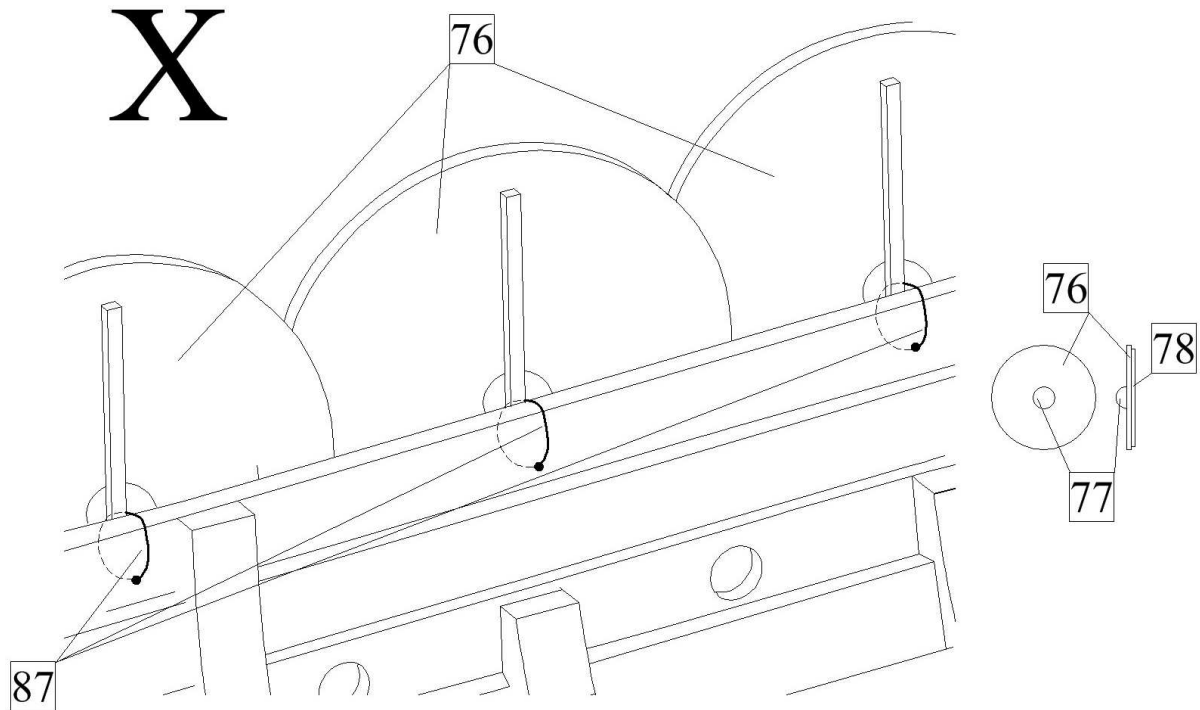

XI) Oars:

From 3mm dowels make oars 79 and a rod 82. First sharpen by a needle file handles of the oars. Then sharpen by a sand paper a middle part of the oars. Finally sharpen by a sand paper also blades of the oars. The oar is in 1:1 scale shown in the plan. The rod 82 sharpen by a sand paper into conical shape. The bar 82 is also in 1:1 scale shown in the plan.

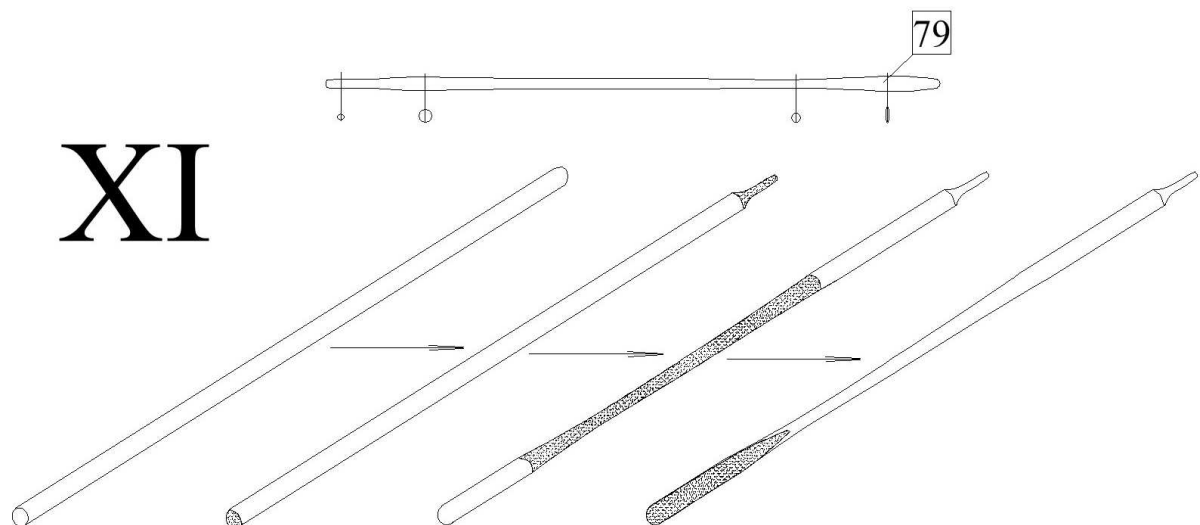

XII) Sail:

a) Make a sail 39. First draw by pencil contours of the sail on the. To the border of the sails add about 10mm for fell. By the pencil draw on the cloth also seams which divided the sail into simple segments. Then scissor the sail with fells and sewn it like it is shown below.

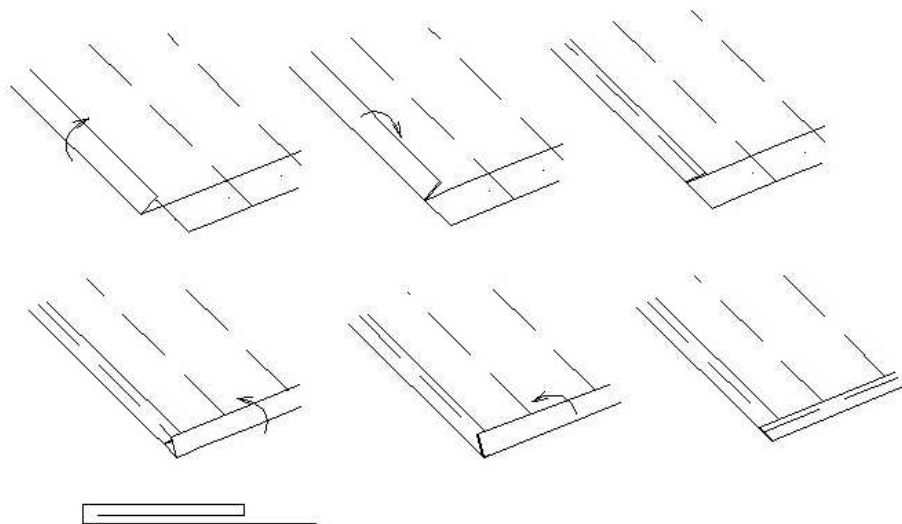
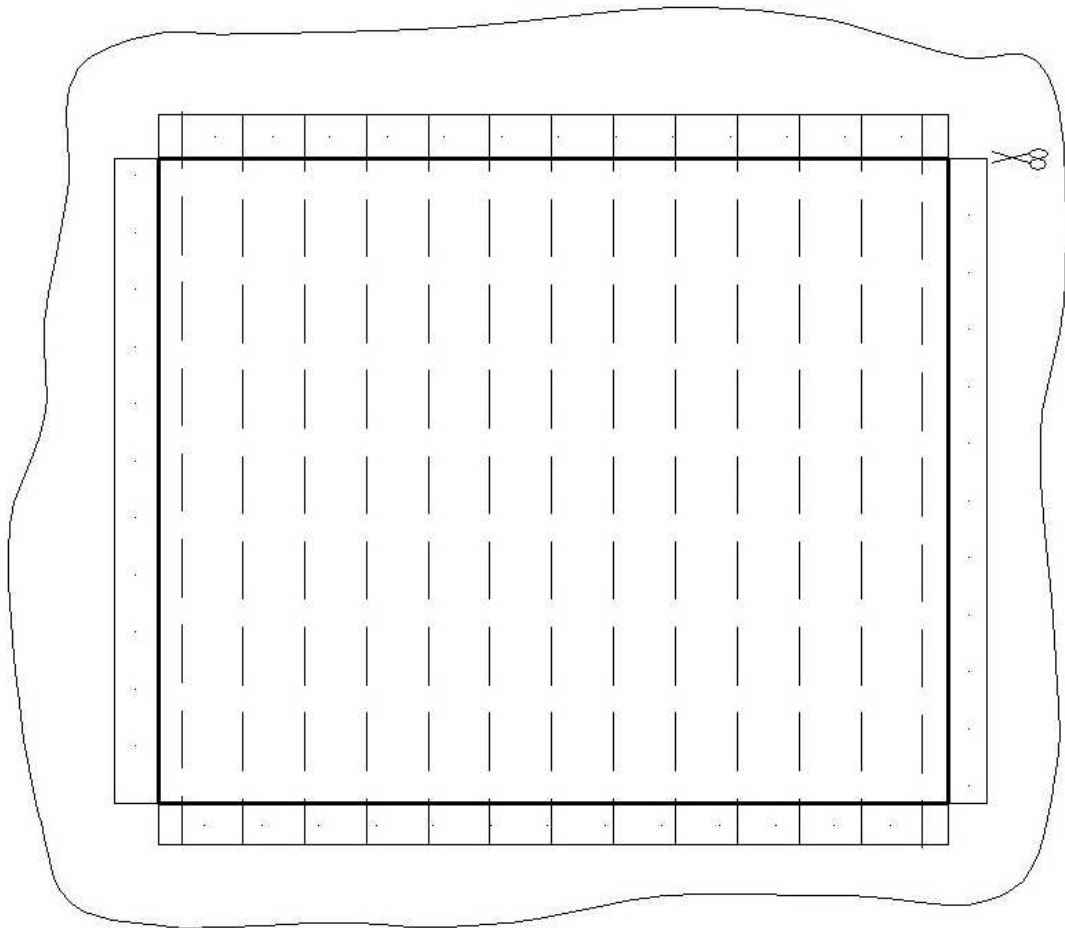

XIIa

b) To the circumference of the sail sew on a rope 93 so that in the corner of the sail will eyes with diameters about 3mm. Then tie the sail to the yard by a rope 86.

XIIb

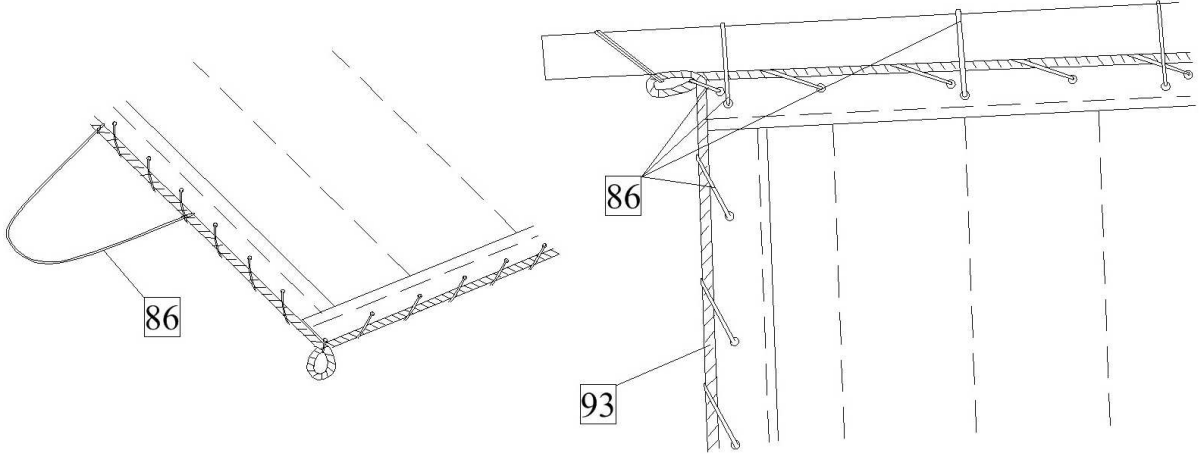

c) Tie the sail by ropes 86 to the hull.

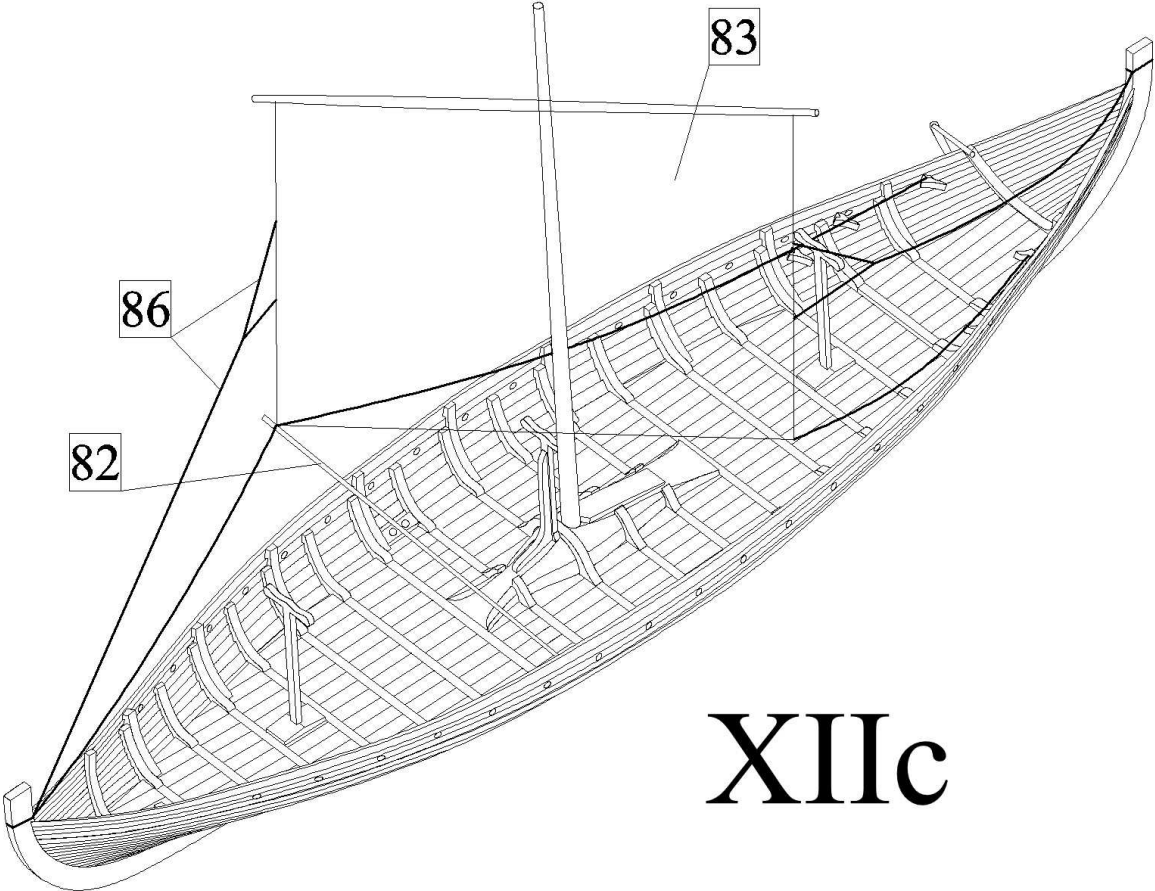

XIIc

XIII) Stand:

Make a stand from parts 90-92. A side view of the stand is in 1:1 scale shown in the plan.

XIII

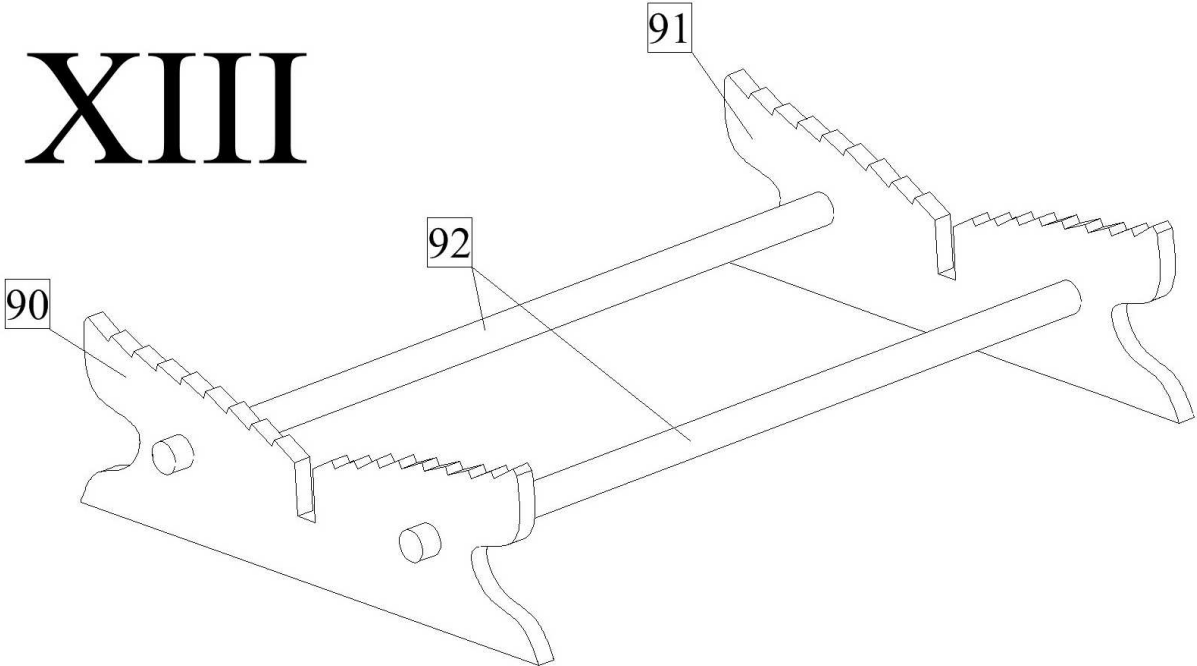

Part list:

0	Keel	plywood 4mm	1pc
1-19	Frames	plywood 4mm	1 pc
2a-18a	Frames	plywood 4mm	2 pcs
20-21	Deck	plywood 1mm	1 pc
22-38	Deck	veneer 0,5mm	5 pcs
39-54	Planking	plywood 1mm	2 pcs
55	Deck	veneer 0,5mm	1ks
56	Cleats	plywood 1.5mm	6 pcs
57	Supports	plywood 4mm	2 pcs
58-62	Mast foot	plywood 4mm	2 pcs
63-65	Reinforcements	plywood 4mm	2 pcs
66	Reinforcements	plywood 4mm	1 pc
67a,b	Supports	plywood 4mm	2 pcs
68a,b	Supports	plywood 4mm	1 pc
69	Supports	plywood 4mm	1 pc
70	Mast	dowel 8mm	2 pcs
71	Yard	dowel 6mm	1 pc
72	Board	plywood 4mm	1 pc
73	Rudder	dowel 8mm	2 pcs
74	Rudder	plywood 4mm	1 pc
75	Rudder	dowel 3mm	12 pcs
76	Shields	plywood 1mm	64 pcs
77	Shields	brass parts	64 pcs
78	Shields	strip 1x1mm	4 pcs
79	Oars	dowel 3mm	12 pcs
80	Rudder	strip 2x4mm	1 pc
81	Boards with holes	plywood 4mm	2 pcs
82	Bar	dowel 3mm	12 pcs
83	Sail	cloth	1 pc
84	Shroud blocks	plywood 1,5mm	5 pcs
85	Pin	strip 1x1mm	4 pcs
86	Rigging	rope 0,75mm	20 m
87	Rigging	rope 0,25mm	20 m
88	Block	block 2 holes	1 pc
89	Blocks	block 1 hole	2 pcs
90,91	Stand	plywood 4mm	1 pc
92	Stand	dowel 8mm	2 pcs
93	Rigging	rope 1,3mm	5 m